



# OUTDOOR EQUIPMENT

SERVING THE FOOD INDUSTRY SINCE 1951

## PATIO HEATER WITH TANK DOOR AND TABLE

Item: 43595

Model: PH-CN-0014



Features easy move wheels and Anti-tip mechanism. Adjustable heat and comes with a push button ignition. Can accommodate a 20 or 30 lb propane tank.

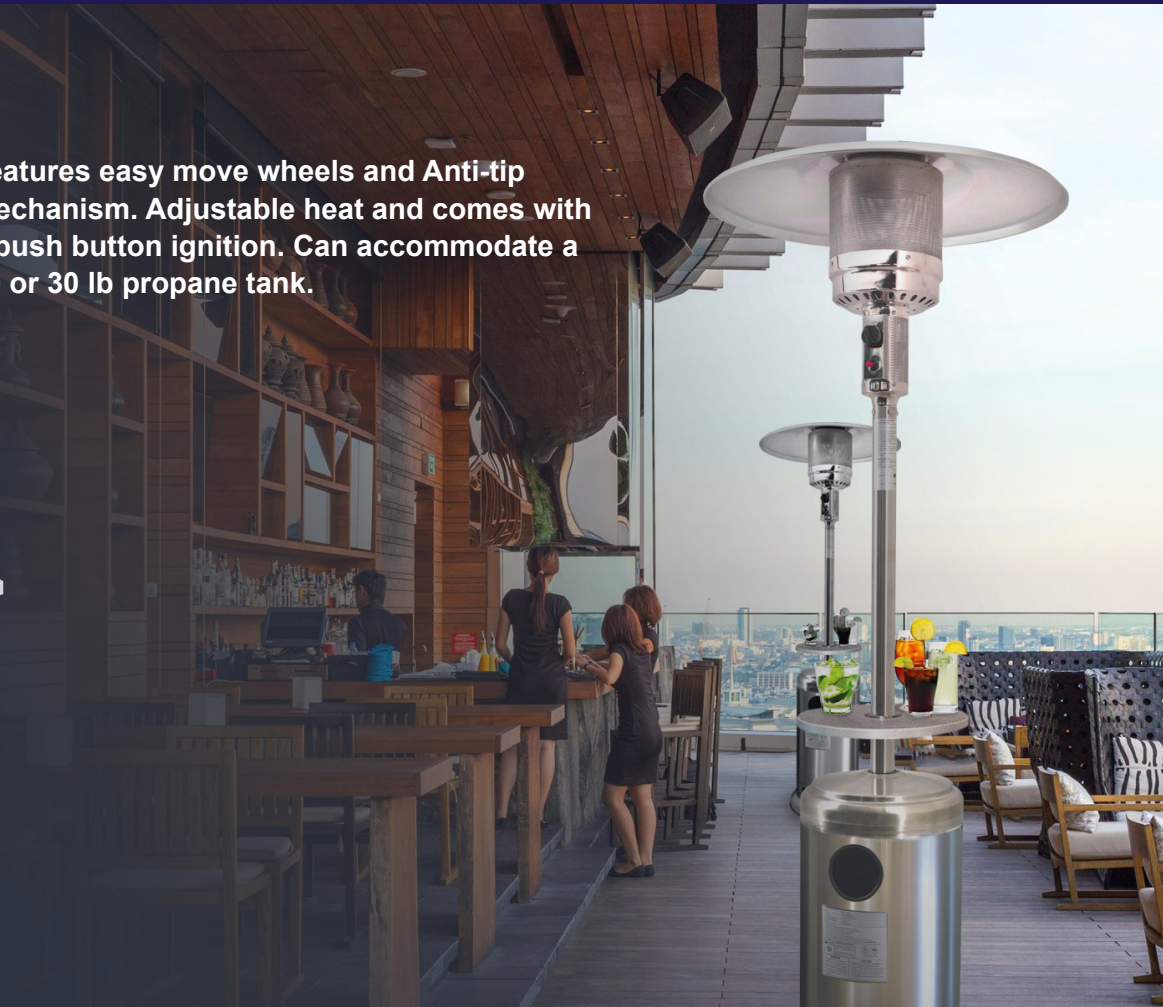

**WARRANTY**  
PARTS AND LABOR



Factory CSA approved



Authorized Dealer

# OUTDOOR EQUIPMENT

## PATIO HEATER WITH TANK DOOR AND TABLE

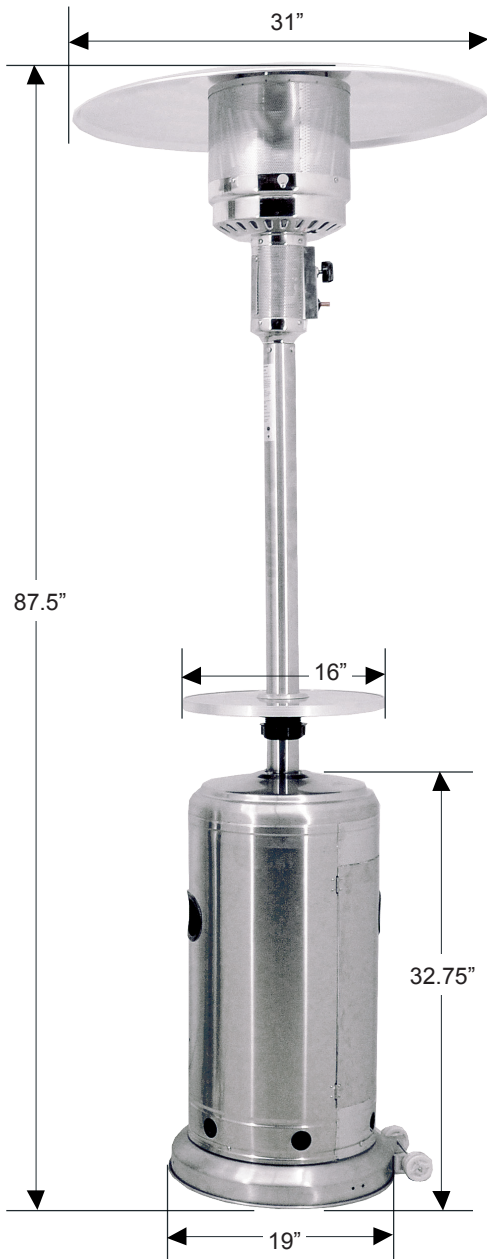

### TECHNICAL SPECIFICATIONS

ITEM NUMBER	<b>43595</b>
MODEL	PH-CN-0014
MATERIAL	Stainless Steel
SAFETY FEATURES	100% Burner shut-off
BTU	41,000 BTU
HEAT RANGE	Up to 20 foot diameter
FUEL	Use propane or butane gas only
INLET GAS SUPPLY PRESSURE	Maximum - 10.5" / 266.7 mm W.C. Minimum- 7" / 177.8 mm W.C.
GAS SUPPLY PRESSURE	120 PSI
CONSUMPTION	450g/hr - 870g/hr
WEIGHT	42 lbs. / 19 kg
GROSS WEIGHT	1st box: 40 lbs. / 18 kg. 2nd box: 2 lbs. / 1 kg.
DIMENSIONS (Dia. x H)	31" x 87.5" / 787.4 x 2222.5 mm



 Factory CSA approved

## OMCAN INC.

Telephone: 1-800-465-0234  
 Fax: (905) 607-0234  
 Email: sales@omcan.com  
 Website: www.omcan.com



Follow us to keep up to date with the latest news and offers



2015.E.O.E